

Universal Medical Screw Driving Systems

Complete Integrated Engineered Solutions



ISO Certified Contract Manufacturer

**Recognized Worldwide For Superior Quality & Precision Machining
Your Source For Medical Instruments & Gages**



• Proven Quality & Service

Universal is a worldwide leader in the contract design and manufacture of Self-Retaining Screw Instruments and Medical Gages for the orthopedic and dental markets. Working in partnership with medical device manufacturers around the world, we provide innovative design & development, advanced machining technology, instrument and gage manufacturing, laser etching and surface treatment services.

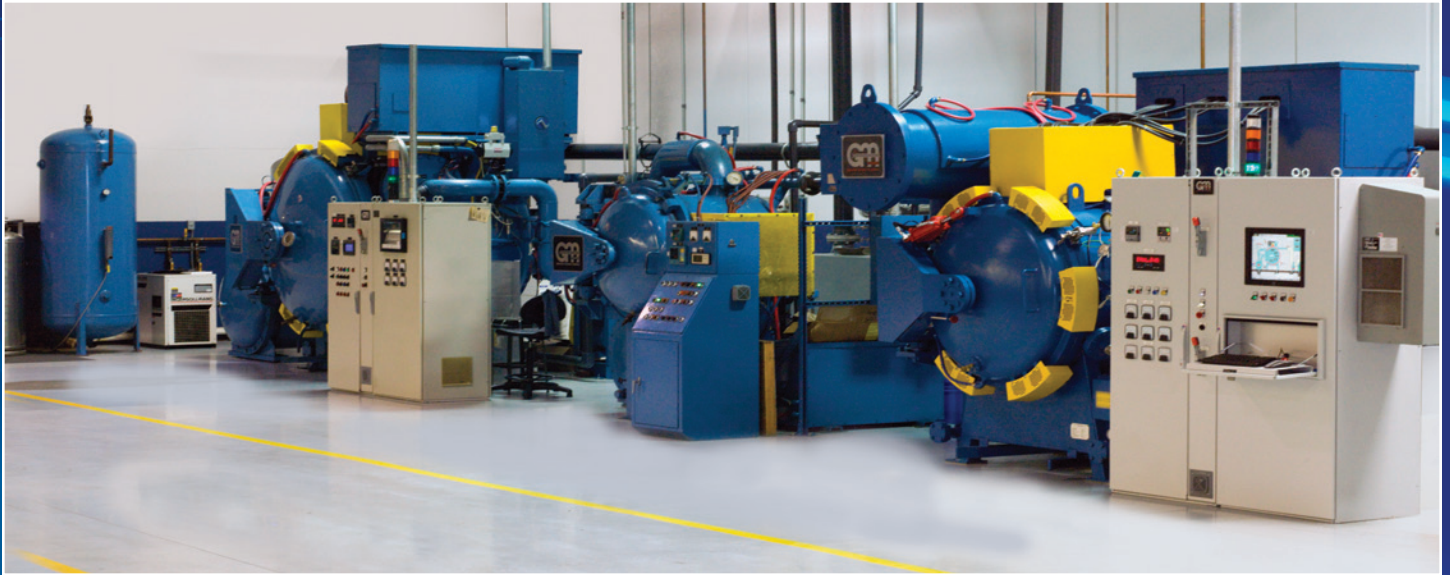

• Machining Capabilities

Whether for small, ultra-precise parts – or the finest surgical instruments, components and gages – partnering with Universal provides superior craftsmanship to produce the kind of overall quality and excellence that sets Universal apart.

- The latest in machining technology, including CNC Swiss Turning Centers, 4 & 5 Axis Milling Centers, Autoloaders CNC 6-Axis Grinding, CNC Centerless Grinders and wire EDM and Conventional EDM machines, as well as automated measuring systems.
- Special processes: like color coding, laser welding, cutting and etching, diamond coating, chrome plating, gundrilling, electropolish, micro deburring and passivation.

- CNC Swiss Turning Centers
- CNC 4 & 5 Axis Milling Centers
- CNC 6-Axis Flute Grinders
- CNC I.D. & O.D. Grinders
- CNC Centerless Grinders
- CNC Lathes
- CNC Wire EDM Machines
- Conventional EDM Machines
- Forging with Induction Heating
- Vacuum Heat Treating



• Engineering Support

•Engineering support including material selection, research & development, prototypes, and custom gages for complete integration between screw and driver. Our engineering staff has significant experience with medical products, as well as tools and gages for the fastener, aerospace, automotive and munitions industries, which gives us a wide range of knowledge to draw from.



• Full Service Partner

A partnership with Universal provides the product development and quality system resources you need to complement and expand your internal capabilities. A full service provider, we can handle your orthopedic project and provide the expertise to ensure you bring quality product to market.

Universal's engineering and manufacturing expertise with product development, and on-site prototyping and testing allows for a rapid transition to full-scale production. Our engineers work side by side with our prototyping team to efficiently integrate and refine your designs. As a contract manufacturer we understand the proprietary nature of our customer's products and confidentiality is guaranteed.



Project Support For:

- Surgical Screwdrivers and Bits
- Tooling & Gages for Medical Screws
- Custom Gages for Special Drivers
- Production Bur, and Drill Grinding
- Design Troubleshooting
- Reverse Engineering
- Engineering for Prototypes
- On-Going Production Requirements



Threads (mm)

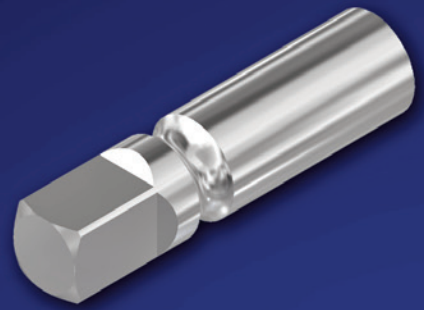

3/16" or 1/4" Square Quicklock



A-O Drive

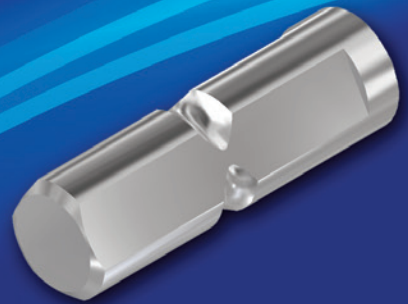

Tri-Flat or Tri-Lobe



Hudson Small

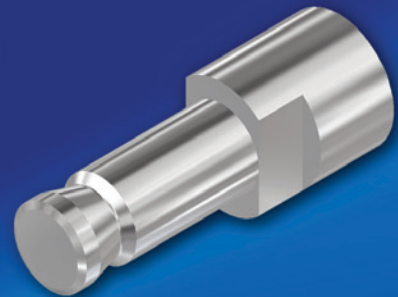

Hudson Large

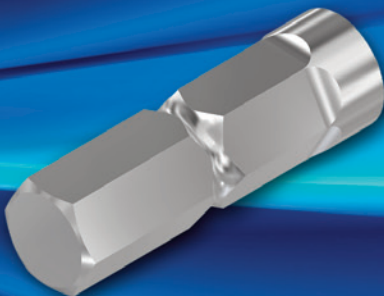

Hex Drive (mm)

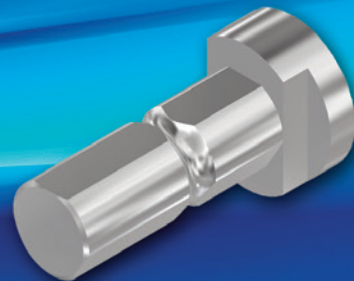

Jacob-Hall or Zimmer-Hall

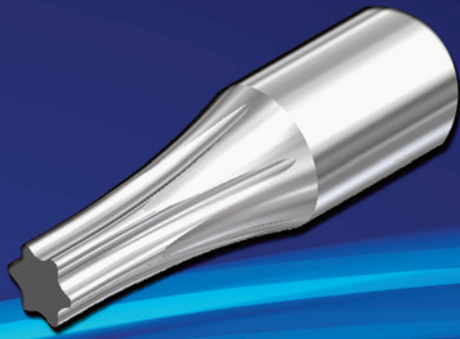

Hexalobe

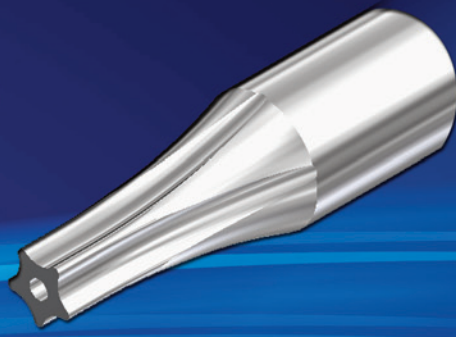

Five-Lobe



6-Lobe Plus

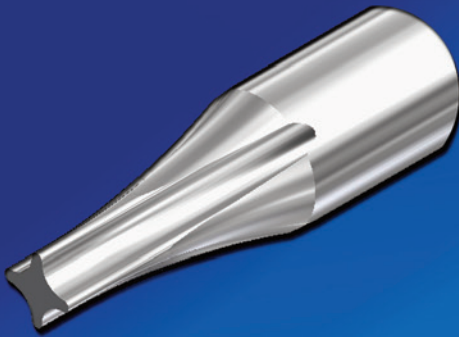

Four-Lobe



Pentagon

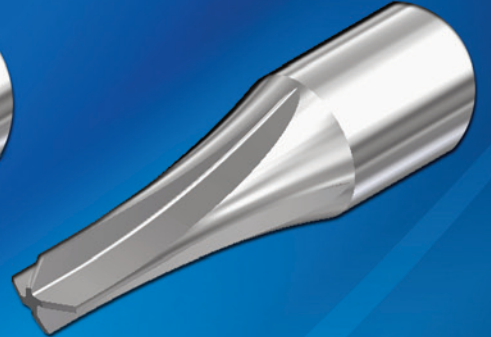

Cruciform / Torque-Set

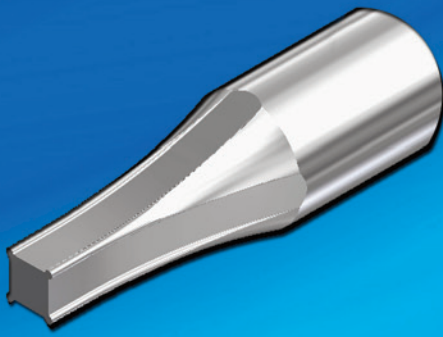

Modified Square

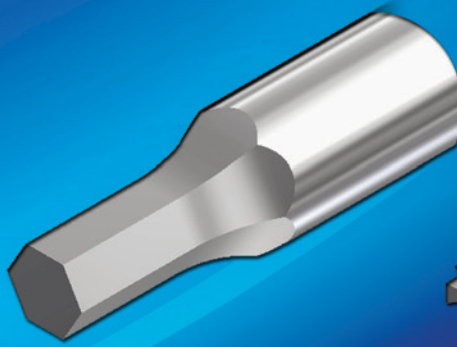

Hexagon (mm)

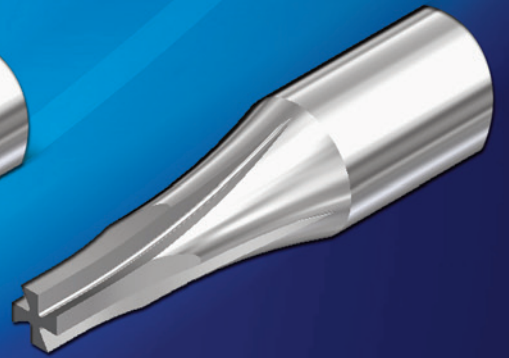

Torque Plus Drive

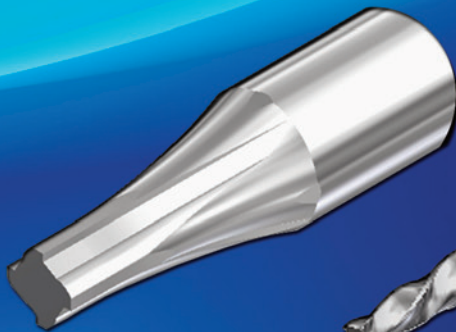

MoreTorque

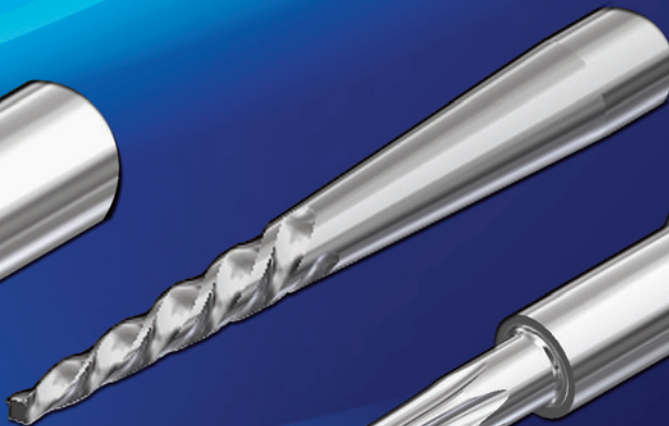

Extractor

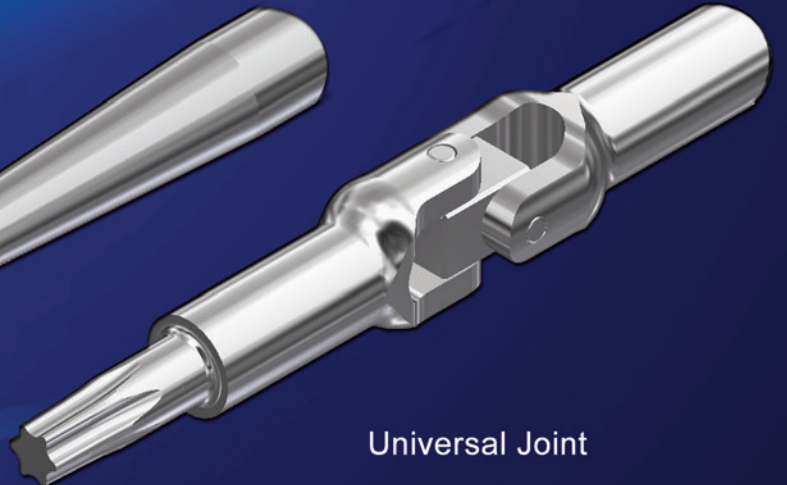

Universal Joint

• Self-Retaining Screwdriver Blades & Bits

Single piece, surgical stainless steel construction for optimum durability, Universal's driver tips have precision tapers to control insertion and retention. Available in a variety of driver configurations including hexalobular, hexagon, 12-point, cruciform and flat-tip. Custom tips quoted upon request.



• Medical Screw & Driver Integrated Solutions

Universal has nearly four decades of experience in the design and manufacture of screwdrivers for orthopedic surgical procedures. Our experience has allowed us to provide complete integrated solutions for superior fit between driver and screw. We can provide the tooling and gages for producing medical screws, as well as the driver and driver gages to assure proper fit and driver retention.

Custom designed for your implants and your procedure, we take your design inputs and provide you with detailed drawings of your instruments and gages to complete your total system. Based on years of manufacturing experience with materials including titanium and surgical grade stainless steels and peek, Universal leads the way for the highest quality self-retaining surgical screwdrivers.

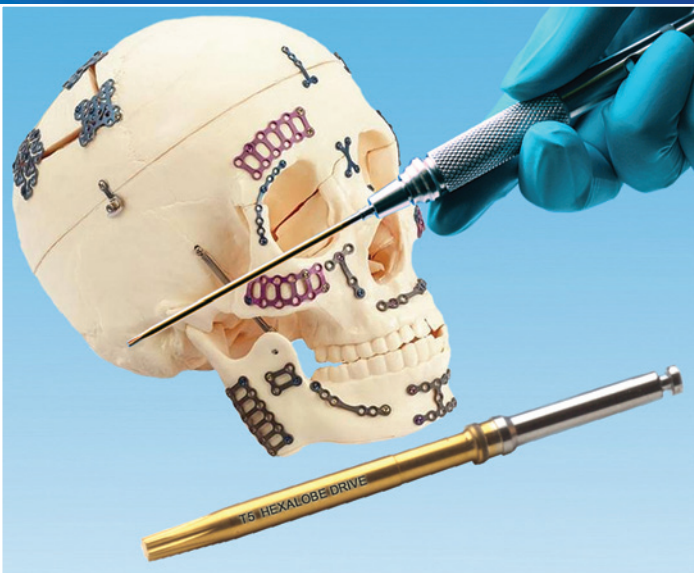

- Single Sourcing
- Controlled Development Costs
- Lean Manufacturing
- Dedicated Prototype Development
- Orthopedics Focused
- ISO 9001:2008 Certified
- ISO 13485:2003 Compliant
- ISO 17025 Compliant
- A Full Service Partner

• Quality Policy

The Universal Quality Policy is our promise to you: "The Universal Team is committed to complete customer satisfaction. This commitment and compliance with our quality management system drives continuous improvement in the ways we serve our customers." • Internal, customer and registrar quality system audits ensure compliance with standards.



• Quality System

Universal supplies world-class quality with every product and service we deliver. Certified to the requirements of ISO 9001:2008 and compliant with ISO13485:2003, our goal is a shared commitment to meet or exceed our customer's requirements and ensure that these standards are maintained at every level of our organization. • State-of-the-art inspection facilities and equipment with instrument uncertainty to 2 millionths of an inch (50 nanometers) • Process Validation • Continuous training programs for quality personnel.

Our years of experience with medical drivers, instruments and gages, coupled with our state-of-the-art facility sets us apart. Together with our knowledgeable staff, and ISO-certified quality systems, we offer you the highest possible achievement in processes, documentation and products. All masters are certified and traceable to N.I.S.T.

Team Certifications:

- Certified Quality Engineers (CQE)
- Certified Quality Auditors (CQA)
- Certified Quality Technicians (CQT)

Inspection Equipment:

- CMM's with Fiberoptic Probes
- Optical Video Systems
- SIP Super Micrometer 0.0025 μ
- Laser Vision System 0.010 μ





Universal Punch Corp., an ISO 9001 registered company, has been a leader in the medical, tooling and gaging industries for nearly four decades. As part of our continuing commitment to providing precision and excellence in all of our products we have expanded into a new state of the art manufacturing facility. Our spacious new plant is equipped with modern machining processes, expanded heat treating facilities, hi-tech coatings and platings, increased inventory capacity, calibration and inspection laboratory. Our certified quality management system is compliant with ISO 13485 and ensures that all products sold conform to the required standards. All measuring equipment and gaging masters are directly traceable to N.I.S.T. All certification processes and procedures conform to guide ISO17025.



PRECISION MEASUREMENTS



INSPECTION LABORATORY



UNIVERSAL PUNCH CORP.

4001 W. MACARTHUR BLVD. • SANTA ANA • CALIFORNIA 92704

phone: (714) 556-4488 telefax: (714) 556-6314

e-mail: sales@universalpunch.com <http://www.universalpunch.com>